

## 15. LIGHTING INSTRUCTIONS

FOR YOUR SAFETY READ BEFORE LIGHTING

**WARNING: IF YOU DO NOT FOLLOW THESE INSTRUCTIONS EXACTLY, A FIRE OR EXPLOSION MAY RESULT CAUSING PROPERTY DAMAGE, PERSONAL INJURY OR LOSS OF LIFE.**

This appliance has a pilot. When lighting the pilot, follow these instructions exactly.

**BEFORE OPERATING**, smell all around the appliance area for gas. Be sure to smell next to the floor because LP gas is heavier than air and will settle on the floor.

### WHAT TO DO IF YOU SMELL GAS:

Do not try to light any gas appliance.

Do not touch any electric switch; do not use any phone in your building.

Immediately call your gas supplier from a neighbor's phone. Follow the gas supplier's instructions.

If you cannot reach your gas supplier, call the fire department.

Use only your hand to push in or turn the gas control knob. Never use tools. If the knob will not push in or turn by hand, don't try to repair it. Call a qualified service technician. Force or attempted repair may result in fire or explosion.

Do not use this appliance if any part has been under water. Immediately call a qualified service technician to inspect the appliance and to replace any part of the control system and any gas control that has been under water.

**BEFORE LIGHTING YOUR STOVE READ THESE INSTRUCTIONS CAREFULLY!  
DO NOT LIGHT THE STOVE IF YOU SMELL GAS!**

### TO LIGHT THE PILOT

1. PUSH THE GAS CONTROL KNOB IN COMPLETELY AND WHILE THE KNOB IS PUSHED IN, TURN IT **REPEATEDLY** COUNTERCLOCKWISE FROM "IGN" TO "PILOT". EACH TIME YOU TURN THE KNOB TO "PILOT" YOU WILL HEAR A CLICK AS IT PRODUCES A SPARK.

– When you push the control knob in, you are letting gas into the firebox.  
– Each time you turn the knob to the left and hear a click, you are producing a spark.

2. IF THE PILOT DOES NOT LIGHT IN THE FIRST 5-6 SECONDS, **STOP**.

– Turn the control knob to the "OFF" position. Wait 5 minutes for the gas to dissipate before attempting to light the stove again.

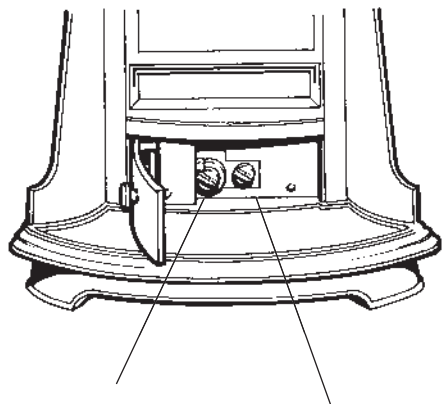

Flame adjustment knob

Gas control knob

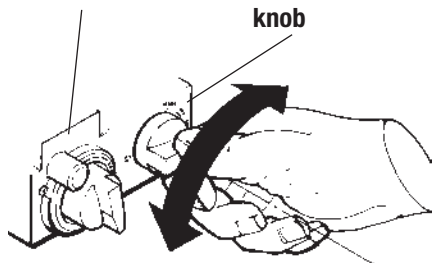

The knob on the right lights the pilot and the main burner. The knob on the left controls flame height and burner On/Off.

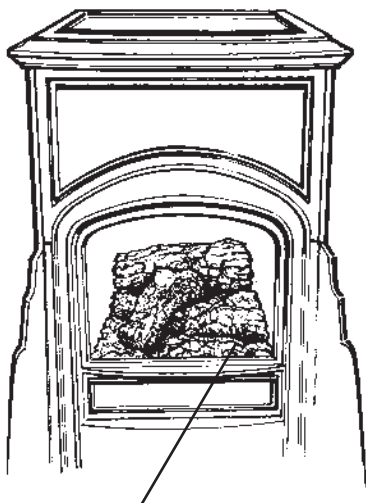

Look for Pilot here.

– If you attempt to light the stove too soon the accumulated gas will ignite, causing an explosion.

### 3. WHEN THE PILOT LIGHTS, CONTINUE TO HOLD THE KNOB IN FOR 10 SECONDS SO THE PILOT WILL STAY LIT.

- When the pilot lights a small flame will be visible below the logset at the right front corner of the firebox.
- Depressing the gas control for 10 seconds after the pilot is lit warms the thermocouple.
- Release the knob. The pilot will remain lit.

### TO LIGHT THE BURNER

#### 1. CONFIRM THE PILOT IS LIT.

- The pilot must be lit before the burner will light.
- Follow instructions above if pilot is not lit.

#### 2. TURN THE GAS CONTROL KNOB COUNTERCLOCKWISE FROM "PILOT" TO "ON". THE BURNER WILL IGNITE

- If flames do not appear in 10 seconds it may be necessary to turn the flame adjustment (left) knob counterclockwise until flames appear.

NOTE: Flame height can be controlled manually at the control panel using the left knob, or with the optional remote control.

NOTE: Knob cannot be turned from "PILOT" to "OFF" unless depressed slightly. Do not force or use tools.

### TO TURN OFF GAS TO APPLIANCE

To turn the main burner off manually turn the ON-PILOT-OFF knob clockwise to pilot. In this position the flames from the main burner will be extinguished, but the pilot will remain lit. The left flame adjustment knob may also be used to turn the burner off by turning it clockwise until it stops. The optional remote control can also extinguish the main burner by simply holding the flame adjustment button in the LO position until the flames go out.

**CAUTION; HOT WHILE IN OPERATION. DO NOT TOUCH. KEEP CHILDREN, CLOTHING, FURNITURE, GASOLINE AND OTHER LIQUIDS HAVING FLAMMABLE VAPORS AWAY.**

**WARNING:** Improper installation, adjustment, alteration, service or maintenance can cause injury or property damage. Refer to the owner's information manual provided with this appliance. For assistance or additional information consult a qualified installer, service agency or the gas supplier.

**CAUTION:** Do not operate this appliance with glass removed, cracked or broken. Replacement of the panel(s) should be done by a licensed or qualified service person.

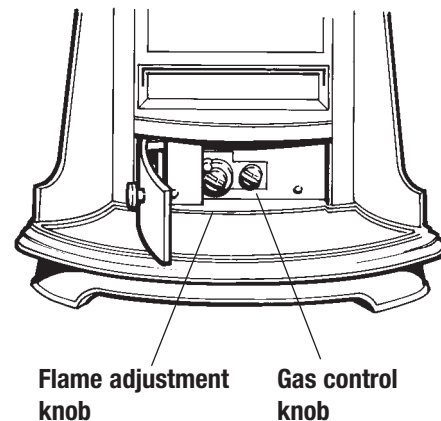

Illustration 15.2 To ignite the pilot, use the two controls indicated above.

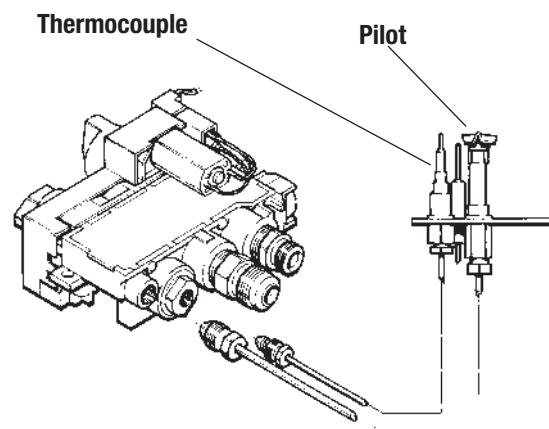

Illustration 15.3 The pilot is located next to the thermocouple. The pilot flame is visible on the right side of the firebox.

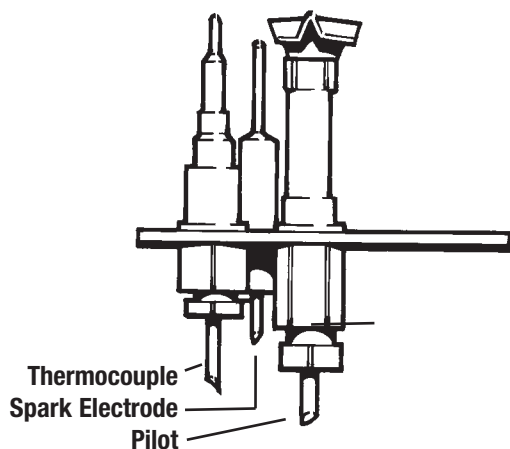

Illustration 15.4 *The pilot assembly is located on the right side of the firebox.*

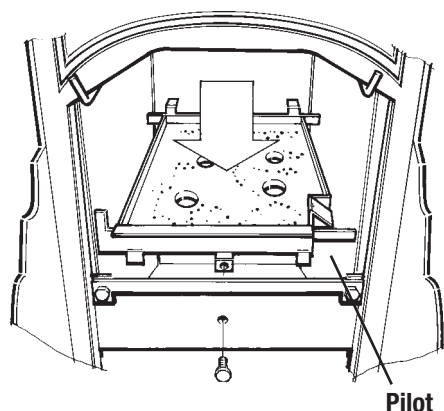

Illustration 15.5 *When the pilot is lit, the flame will be clearly visible at the right side of the firebox, beneath the right side of the burner pan.*

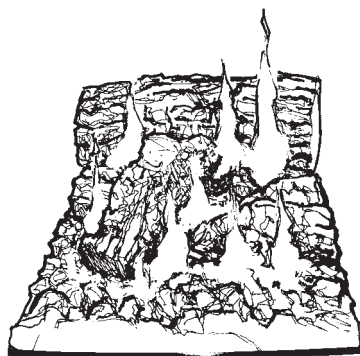

Illustration 15.6 *After the fire has burned for 15 minutes the flames should be evenly distributed and have a mostly yellow appearance.*

### Technical Note:

**HOW THE PILOT SAFETY CONTROL WORKS:** When lit, the pilot flame warms a thermocouple. The heated thermocouple produces a small electrical current that activates an electromagnet which keeps the pilot gas supply valve open. When you hold down the control knob after the pilot initially lights, you are manually keeping open the gas supply until the thermocouple warms up enough to automatically keep the gas supply valve open.

Should the pilot blow out, the thermocouple will cool and the electromagnet will close the gas supply valve and shut off the supply of gas. If pilot goes out after being lit long enough to warm the thermocouple, the thermocouple must cool down before the electromagnet will allow the gas valve to reopen. This safety mechanism can take up to 30 seconds and produces an audible “click”.

### ADDITIONAL NOTES

1. Check that the flames are evenly distributed. (See illustration 15.6.) in LP burning stoves they will be mostly blue for the first 15 minutes and then will change to yellow/orange. NG stoves will remain very blue/translucent. There may be a slight amount of condensation on the glass. This will disappear when the fireplace heats up.
2. If this is the first time you have burned your new fireplace for any length of time, you may smell the fireplace paint curing. This is normal and will go away within a few hours.
3. The adhesive on the window gasket will also take a few days to cure. This process will create an unpleasant odor. This is normal and will go away after about 10 to 12 hours of use on High.
4. **To completely shut off the Stove**, including the pilot, turn the Gas Control Knob to the “OFF” position. It is a good idea to turn the Gas Control Knob to “OFF” and turn the manual gas valve on the supply line to “OFF” if the stove will not be used for any length of time. This turns off the pilot, the burner, and the gas supply.

### WARNING

Do not attempt to decrease flame size or heat output by closing the manual gas supply valve. This valve should always be in a fully open position.

## 16. SAFETY INSTRUCTIONS

### FOR YOUR SAFETY READ BEFORE OPERATING

**WARNING:** If you do not follow these instructions exactly, a fire or explosion may result causing property damage, personal injury, or loss of life.

- A. This appliance has a pilot. When lighting the pilot, follow these instructions exactly.
- B. **BEFORE OPERATING** smell all around the appliance area for gas. Be sure to smell next to the floor because some gas is heavier than air and will settle on the floor.

#### WHAT TO DO IF YOU SMELL GAS

- Do not try to light any gas appliance.

- Do not touch any electric switch; do not use any phone in your building.
  - Immediately call your gas supplier from a neighbor's phone. Follow the gas supplier's instructions.
  - If you cannot reach your gas supplier. Call the fire department.
- C. Use only your hand to push in or turn the gas control knob. Never use tools. If the knob will not push in or

turn by hand, don't try to repair it. Call a qualified service technician. Force or attempted repair may result in a fire or explosion.

- D. Do not use this appliance if any part has been under water. Immediately call a qualified service technician to inspect the appliance and to replace any part of the control system and any gas control that has been under water.

### LIGHTING INSTRUCTIONS

1. STOP! Read the safety information on the panel above.

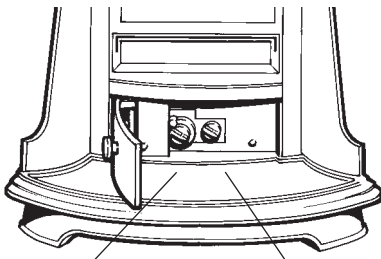

Flame adjustment knob      Gas control knob

2. Push in gas control knob slightly and turn clockwise  to "OFF". NOTE: Knob cannot be turned from "PILOT" to "OFF" unless knob is pushed in slightly. Do not force.
3. Wait five (5) minutes to clear out any gas. If you then smell gas. STOP! Follow "B" in the safety information above on this label. If you don't smell gas, go to the next step.

4. Push gas control knob in completely and turn counterclockwise  repeatedly from "IGN" to "PILOT". (audible click)

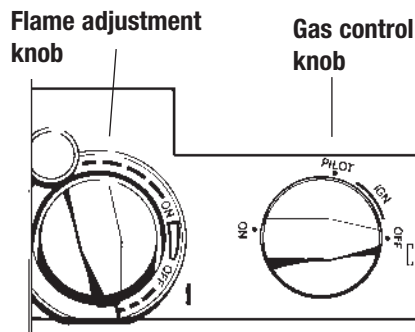

5. Find pilot. The pilot is located below the logset in the forward right corner area of the firebox.
6. Continue to hold the control knob in for about 10 seconds after the pilot is lit. Release knob and it will pop back up. Pilot should remain

lit. If it goes out, repeat steps 4 and 5.

- \* If knob does not pop up when released, stop and immediately call your service technician or gas supplier.
- \* If the pilot will not stay lit after several tries, turn the gas control knob to "OFF" and call your

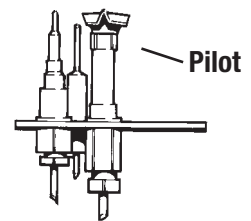

Pilot Burner Assembly

service technician or gas supplier.

7. Turn gas control knob counter clockwise  to ON, turn flame adjustment knob counter clockwise until flames appear.

### TO TURN OFF GAS TO APPLIANCE

Push in gas control knob slightly and turn clockwise  to "OFF."

NOTE: Knob cannot be turned from "PILOT" to "OFF" unless knob is pushed in slightly. Do not force.

Turn manual gas supply valve off if stove will not be used for an extended length of time.