

# REPLACEMENT PARTS

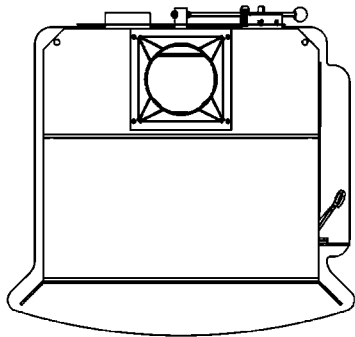

TOP VIEW

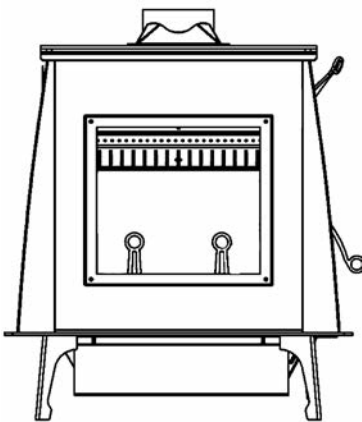
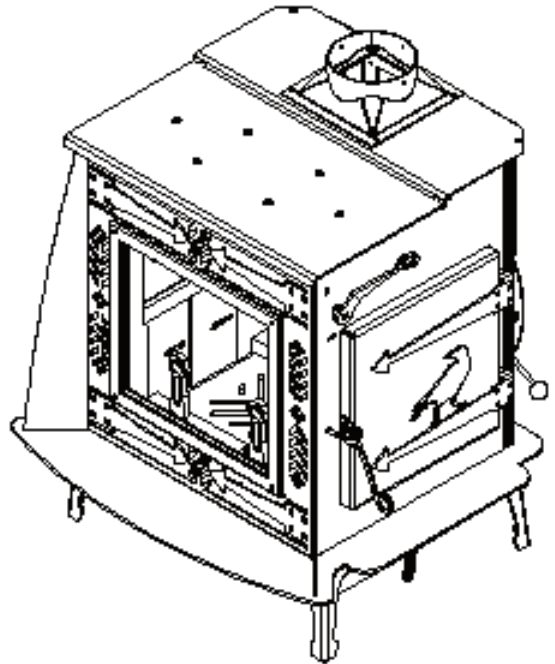

FRONT VIEW

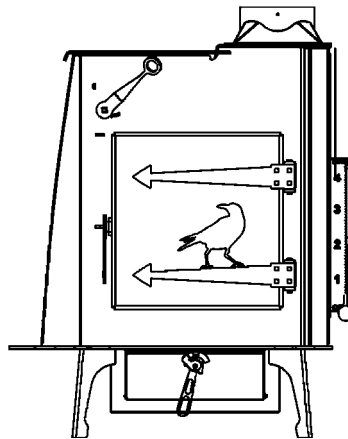

SIDE VIEW

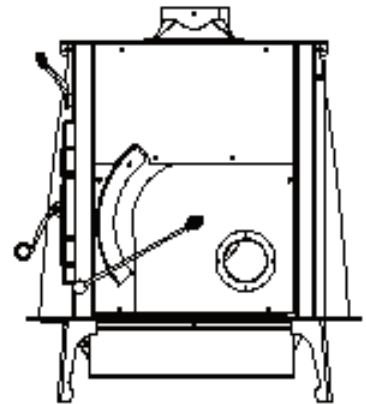

BACK VIEW

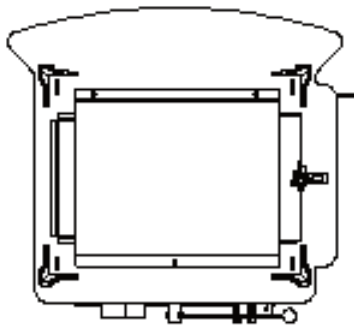

BOTTOM VIEW

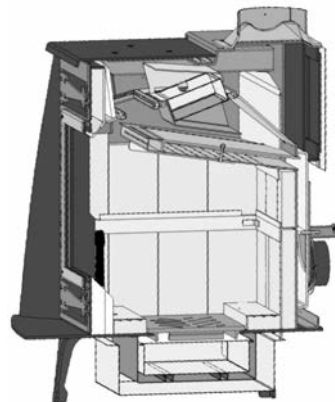

CUT-AWAY VIEW

## REPLACEMENT PARTS

### COMPLETE ASSEMBLIES AVAILABLE AS REPLACEMENT PARTS

PART NO.	DESCRIPTION	QTY/PER	
R-10	DOOR ASSEMBLY	1	
R-18	FLUE COLLAR ASSEMBLY	1	
R-22	AIR INTAKE WHEEL ASSEMBLY	1	
R-26	TOP LID ASSEMBLY	1	
R-30	BRICK RETAINER ASSEMBLY	1	
R-32	ANDIRON HOLDER ASSEMBLY	2	
R-34	PRIMARY JET INLET ASSEMBLY	2	
R-46	RACHET, AIR INTAKE ASSEMBLY	1	
R-48	OUTSIDE AIR ADAPTOR ASSEMBLY	1	
R-50	GRATE ASSEMBLY	1	
R-52	SOAPSTONE LINER ASSEMBLY	1	
R-54	TERTIARY AIR INLET ASSEMBLY	2	

### INDIVIDUAL PARTS AVAILABLE FOR REPLACEMENT

PART NO.	DESCRIPTION	QTY/PER	MATERIAL
R-907	HINGE PIN, DOOR	2	STEEL
R-193	HANDLE, DOOR	1	STEEL
R-925	BYPASS COVER	1	STEEL
R-513	HEAT SHIELD, BYPASS COVER	1	SS
R-935	HANDLE, BYPASS	1	STEEL
R-165	TOP LID	1	STEEL
R-515	HEAT SHIELD, TOP LID	1	SS
R-163	FLUE COVER	1	STEEL
R-145	GLASS RETAINER	1	STEEL
R-904	GLASS, HIGH TEMP: 5 MM CERAMIC	2	GLASS
R-981	ASH PAN (PG-934)	1	STEEL
R-983	ASH PAN COVER (PG-989)	1	STEEL
R-917	HINGE PIN, ASH DOOR	1	STEEL
R-121	HANDLE, ASH DOOR	1	STEEL
R-913	ASH DOOR, OUTER	1	STEEL
R-941	HANDLE, AIR INTAKE	1	STEEL
R-943	KNOB, AIR INTAKE	1	PHENOLIC
R-997	HEAT SHIELD, REAR	1	STEEL
R-995	HEAT SHILD, BOTTOM	1	STEEL
R-523	HOOD, COMBUSTOR	1	SS

### GASKET SPECIFICATIONS

PART	SPECIFICATION		
TOP LID	0.875" MD DENSITY ROPE	64"	
BYPASS	0.625" LD2 BASALT ROPE	42"	
COMBUSTOR	0.625" LD2 BASALT ROPE	38"	
DOOR	0.875" MD DENSITY ROPE	52"	
ASH PAN DOOR	0.500 MD ROPE	32"	
OUTER GLASS	BH .125 X .750 GRAPHITE TAPE /.187 X .750 TAPE	58"	
INNER GLASS	BH .1875 X .750 GRAPHITE TAPE /.187 X .750 TAPE	58"	
FLUE COLLAR	BH .125X.750 GRAPHITE TAPE CUT IN HALF	34"	
FLUE COVER	BH .125X.750 GRAPHITE TAPE CUT IN HALF	34"	
OAA	BH .125X.750 GRAPHITE TAPE CUT IN HALF	121"	

### CATALYTIC COMBUSTOR SPECIFICATIONS

R-56: 5.25" X 10" X 2.125" CANNED DIM. DURAFOIL OR EQUIVALENT. 49 CELLS PER SQ INCH

# INSIDE LINER REPLACEMENT PARTS

## REVISIONS SHEET

DESCRIPTION*	DATE*	APPROVED*

ITEM NO.	PART NUMBER	DESCRIPTION	QTY.	Material	Dim. 1	Dim. 2
1	R-411-151007	BRICK (WHOLE)	7	PURCHASED	4.5	9.0
2	R-413-160802	SOAPSTONE 1-1/4	4	PURCHASED	4-1/2	5
3	R-415-151007	BRICK (2 CUT)	1	PURCHASED	2.13	5
4	R-439-160802	SOAPSTONE 1-1/4	1	PURCHASED	4-3/4	5-1/8
5	R-415-151007	BRICK (1 CUT)	1	PURCHASED	4.5	5.87
6	R-417-151007	BRICK (1 CUT)	4	PURCHASED	4.5	6.63
7	R-439-160802	SOAPSTONE 1-1/4	2	PURCHASED	4	9-1/4
8	R-429-160802	SOAPSTONE 1-1/4	2	PURCHASED	3	8-1/4
9	R-433-160802	SOAPSTONE 1-1/4	2	PURCHASED	2-1/4	5
10	R-421-151007	BRICK (1 CUT)	2	PURCHASED	1.63	9
11	R-429-160802	SOAPSTONE 1-1/4	2	PURCHASED	3.65	9
12	R-429-160802	SOAPSTONE 1-1/4	2	PURCHASED	3-1/4	8-1/4
13	R-429-160802	SOAPSTONE 1-1/4	1	PURCHASED	3-3/4	5
14	R-449-151230	SOAPSTONE (2 CUT)	1	PURCHASED	7.4	7.4
15	R-451-160802	SOAPSTONE 1-1/4	2	PURCHASED	3-3/8	5-1/8 (-45°)
16	R-455-160802	SOAPSTONE 3/4	2	PURCHASED	3-1/4	4 (-45°)
17	R-453-151230	SOAPSTONE (2 CUT)	1	PURCHASED	4 (-45°)	6.9
18	R-419-151007	BRICK (1 CUT)	4	PURCHASED	3	9
19	R-447-151229	BRICK (2 CUT)	2	PURCHASED	3	3

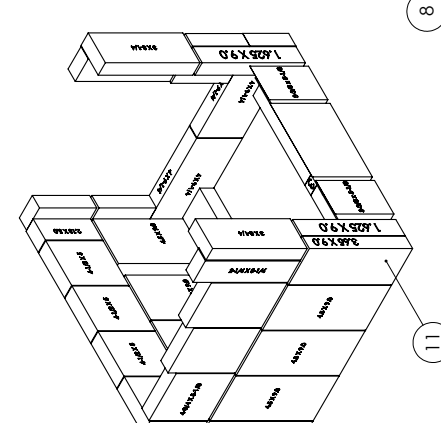
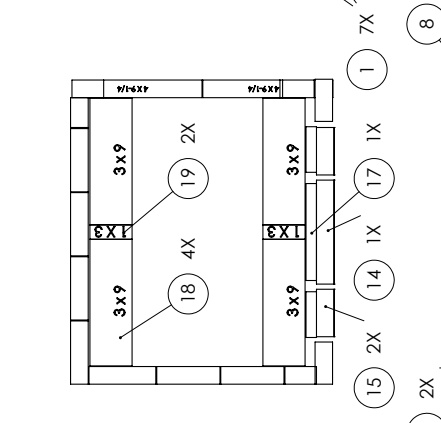
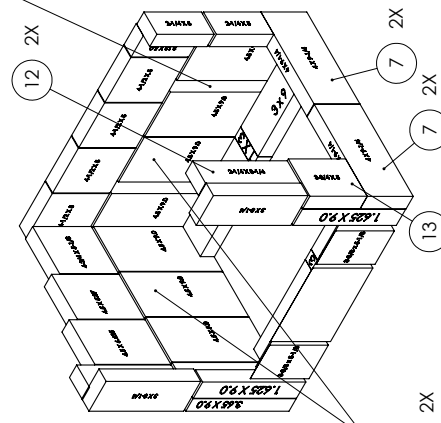
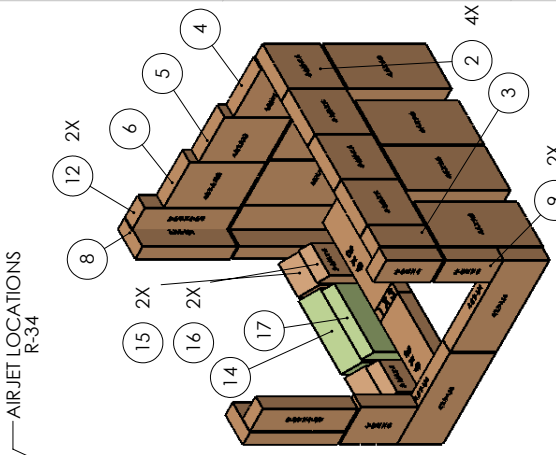

NAME	DATE
WILL J	5/12/2021
MATERIAL	FINISH
FIREBRICK	
DO NOT SCALE DRAWING	
UNLESS OTHERWISE SPECIFIED:	
DIMENSIONS ARE IN INCHES	
FRACTIONAL	
ANGULAR MACH: BEND ±	
TWO PLACE DECIMAL ±	
THREE PLACE DECIMAL ±	

TITLE:	
STONE/BRICK LAYOUT ABSOLUTE	
SIZE	DWG. NO.
B	R-52-160621
SCALE: 1/8"	WEIGHT:
SHEET 1 OF 1	REV

3-1/4 X 9-0	4-1/2 X 9-0	4-1/2 X 9-0	4-1/2 X 9-0
3-1/4 X 9-0	4-1/2 X 9-0	4-1/2 X 9-0	4-1/2 X 9-0
3-1/4 X 9-0	4-1/2 X 9-0	4-1/2 X 9-0	4-1/2 X 9-0
3-1/4 X 9-0	4-1/2 X 9-0	4-1/2 X 9-0	4-1/2 X 9-0

3-1/4 X 9-0	4-1/2 X 9-0	4-1/2 X 9-0	4-1/2 X 9-0
3-1/4 X 9-0	4-1/2 X 9-0	4-1/2 X 9-0	4-1/2 X 9-0
3-1/4 X 9-0	4-1/2 X 9-0	4-1/2 X 9-0	4-1/2 X 9-0
3-1/4 X 9-0	4-1/2 X 9-0	4-1/2 X 9-0	4-1/2 X 9-0

3-1/4 X 9-0	4-1/2 X 9-0	4-1/2 X 9-0	4-1/2 X 9-0
3-1/4 X 9-0	4-1/2 X 9-0	4-1/2 X 9-0	4-1/2 X 9-0
3-1/4 X 9-0	4-1/2 X 9-0	4-1/2 X 9-0	4-1/2 X 9-0
3-1/4 X 9-0	4-1/2 X 9-0	4-1/2 X 9-0	4-1/2 X 9-0

C:\Users\W C Cooke\Desktop\ACTIVE - WSC PART FILES 20190524 - USE THIS! \ABSOLUTE FILES 20190322\PRINTS\

# REPLACEMENT PARTS

## R-34 PRIMARY JET INLET ASSEMBLY

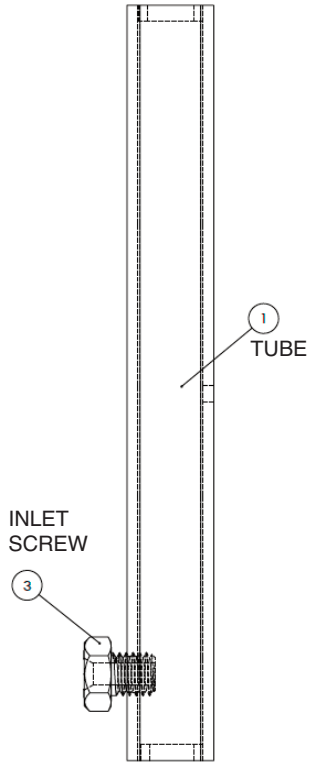

## R-54 TERTIARY AIR INLET ASSEMBLY

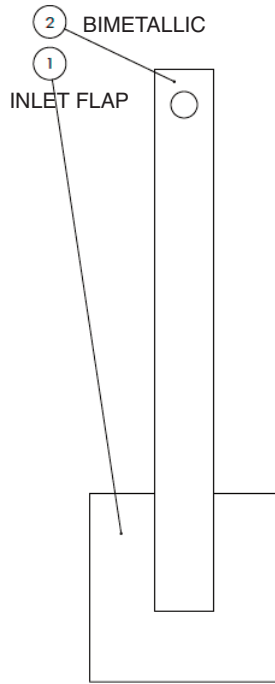

## R-48 OUTSIDE AIR ADAPTOR ASSEMBLY

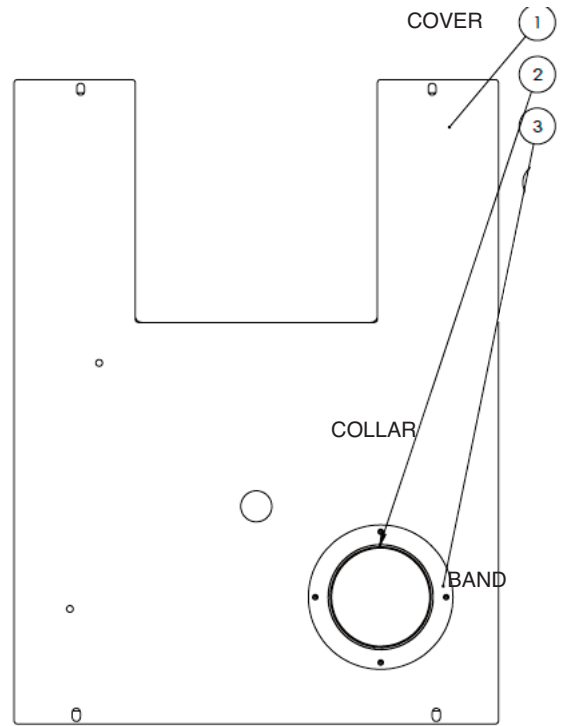

## R-50 GRATE ASSEMBLY

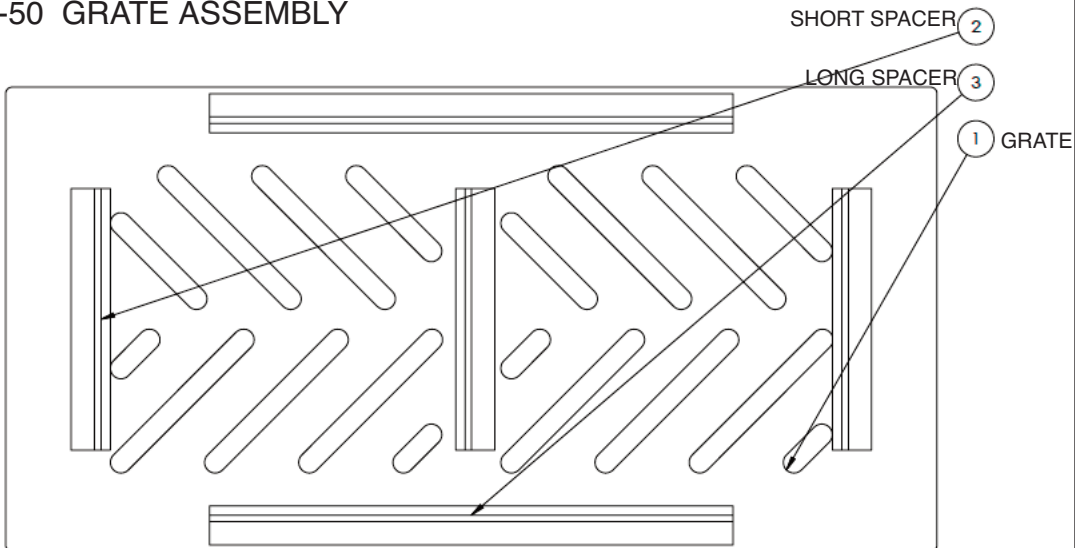

## R-32a ANDIRON

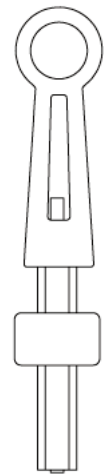

# REPLACEMENT PARTS

## R-22 AIR INTAKE WHEEL ASSEMBLY

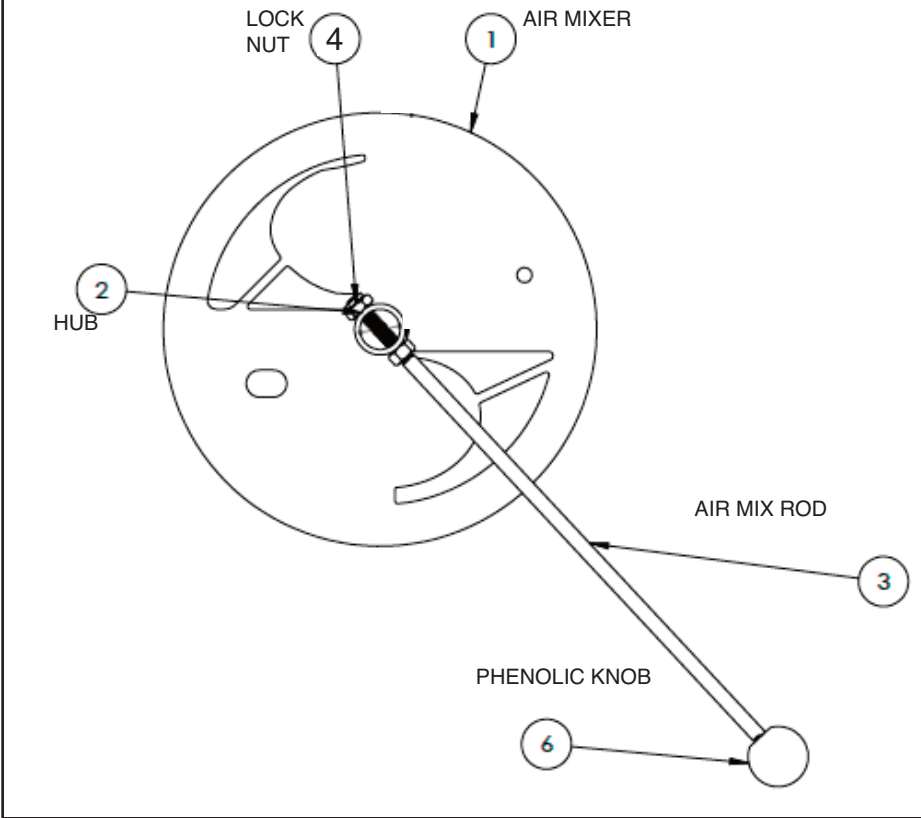

## R-22 BYPASS DAMPER ASSEMBLY

