

THE CATALYTIC COMBUSTOR

Here is how your catalytic combustor works.

The catalytic combustor is a stainless steel honeycomb with hundreds of cells. If you looked at the inside of each cell with a microscope, you would see that the walls are uneven and filled with minute nooks and crannies. Precious metals, such as platinum, are sprayed on the inside of these cells to coat all of the nooks and crannies. This creates the largest possible surface area to interact with the wood smoke. The catalytic combustor in your stove is very similar to the one in the exhaust system of your automobile and works to achieve the same results - high efficiency and clean air!

When you first start a fire, you should bypass your catalytic combustor and let the smoke go directly up the chimney. Once wood smoke reaches 500° F (about 10-15 minutes after reestablishing a strong fire), it is hot enough to ignite the catalytic combustor. As the wood smoke passes through the cells in the combustor, the smoke reacts with the precious metals which line the inside of the honeycomb and both combustible gases and particles in the smoke ignite and burn. This "catalytic burn" reduces emissions and also increases heat output from the stove.

Without a catalytic combustor, between 5% - 40% of the chemical energy contained in wood simply escapes up the chimney when wood is burned. Energy laden gases are exhausted up the chimney where they pollute the air or may condense on the inside of the chimney flue as creosote. The slower the burn, without a catalytic combustor, the greater the amount of energy that is lost. A long smoldering fire is the least efficient use of energy in wood, yet it produces lots of smoke, which is the fuel supply for the catalytic combustor.

Most of the chemical compounds in wood smoke are combustible. The catalyst produces high temperatures, which loosen the bonds of these chemical compounds and "burns" wood smoke. A stove that "burns" these compounds and uses smoke as additional fuel will burn more efficiently and produce more heat, while reducing creosote and air pollution at the same time. However, most stoves cannot consistently produce temperatures high enough to burn cleanly, particularly during long burning times - hence the need for a catalytic combustor.

Your catalytic combustor can get the most efficiency out of every piece of wood if it has three things: temperature, turbulence, and time.

- 1. Temperature.** The catalytic combustor can only start burning the gases in the wood smoke after the smoke has reached at least 500 degrees F. Before the smoke reaches that temperature, it simply is not hot enough to start the reaction at the combustor. This will result in an inefficient smoldering fire.
- 2. Turbulence.** The wood smoke can interact best with the precious metals inside the honeycomb cells if there is some variation in the air flow. Increased turbulence enables more of the wood smoke to come into contact with more of the nooks and crannies in the honeycomb cells. The exhaust path as well as the irregular surface of the combustor cells adds needed turbulence.
- 3. Time.** Once the temperature and turbulence are achieved, the catalytic combustor just needs to have enough time to burn all the gases in the wood smoke. For this reason, it is best to minimize the amount of air you allow into the firebox once the combustor is ignited. Allowing too much air into the firebox speeds up the rate at which the fire burns and allows more wood smoke to be consumed by the secondary combustion system. The ideal air setting for a long catalytic burn allows enough air to keep the wood burning and producing smoke.

With proper care, a new catalytic combustor will give years of fuel savings and lowered emissions. By following some simple guidelines you can ensure maximum combustor performance and longevity. Your catalytic combustor is designed to last for 12,000 -14,000 hours of use. You can ensure yourself of getting the maximum life from your combustor by following these simple guidelines:

- 1) Burn only natural, dry wood.
- 2) Wait until the exhaust gases reach about 500 degrees F before engaging the catalytic combustor (about 5-15 minutes, or 250° on single wall stove pipe, after establishing a strong fire).
- 3) Bypass the combustor before reloading, and leave the bypass open for a few minutes after reloading, to raise the temperature in the stove.
- 4) Don't overfire the stove.
- 5) Clean the combustor regularly. See instructions below.

You can also obtain a lot of useful information by visiting our website (www.woodstove.com). Other very useful web

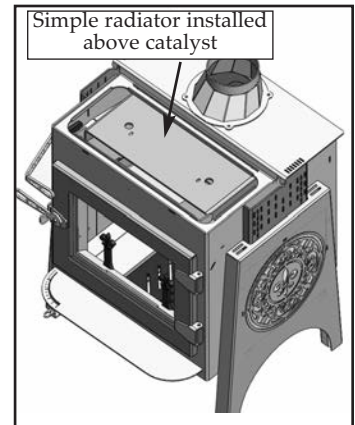

sites on all aspects of wood burning are (www.hearth.com), (www.woodheat.org) and (www.csia.org). CSIA is the Chimney Safety Institute of America.

Inspection & Cleaning

Your stove comes with a new stainless steel combustor already installed. The stainless combustor is a honeycomb foil block located under the top lid of the Ideal Steel . Typical lifespan for a well maintained catalytic combustor is 4-6 years. There are a few ways to determine if your combustor needs to be cleaned. If you notice the smoke exiting your chimney is thicker and darker in color, the combustor may need cleaning. Additionally, if you notice reduced draft or backpuffing, or performance and heat output has diminished, then the combustor may not be working as efficiently as designed.

Plan to clean and inspect your catalytic combustor about every 4-6 weeks. Any fly ash deposits on the combustor will need to be brushed or vacuumed off. An accumulation of fly ash can reduce the draft, causing backpuffing, sluggish burning, and inefficient heating performance. You should clean and check your combustor before the heating season begins, as well as on a regular 4-6 week basis.

COMBUSTOR CLEANING HOW TO:

Tools needed: (1) work gloves and safety glasses; (2) soft bristled paint brush or vacuum cleaner (preferably one designed for ash removal).

1. Be sure the fire is out and the stove is cold. If you are using a regular home vacuum, it is extremely important that no hot ashes or embers be sucked into it as this could result in damage to the vacuum or cause a serious fire. Remove the center burner, if equipped, from the stove. Open the top lid. The combustor is located under the radiator. Lift the radiator up and remove it from the stove.

2. Lift the combustor out of the stove. Brush or vacuum the combustor thoroughly, from both sides. Do not use high pressure compressed air to clean the combustor, as this could damage the reactive coating. Be sure to remove all fly ash from the combustor. Inspect the gasket that the combustor housing rests against.

3. Return the combustor to the stove. Be sure that it is seated properly. Place the radiator over the combustor. Raise and lower the bypass lever to be sure the radiator is seated properly.

4. Close the top lid and return the center burner to the top of the stove.

NOTE: A more thorough cleaning can be done as needed, by following the same directions above. After the combustor is vacuumed or brushed off, rinse (or soak for 10-15 minutes) the combustor with a mixture of 50% white vinegar & 50% distilled water. After rinsing or soaking in the 50/50 mixture, rinse with distilled water. Allow the combustor to dry before reinstalling in the stove.

Catalytic Combustor Replacement

If you feel that your catalytic combustor is not working properly, please contact Woodstock Soapstone Company at 1-800-866-4344 for instructions regarding return and replacement. Accessing the catalyst in your new Ideal Steel Hybrid Woodstove is simple. Just lift the top stove lid. Then remove the radiator (pictured above right) using the two finger holes in the top. You can lift the catalyst plate from the stove.

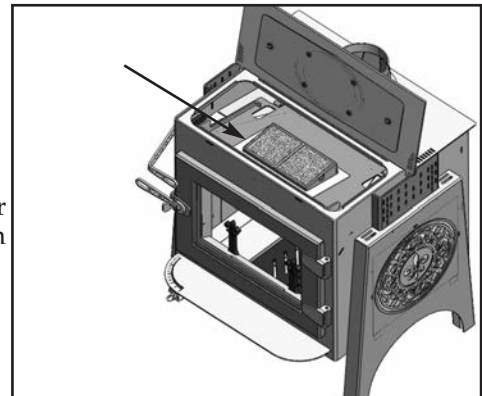
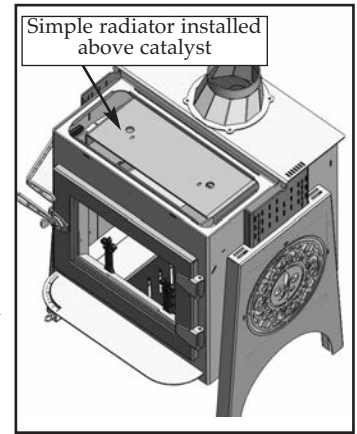

Frequently Asked Questions

Q. How does the catalytic combustor work?

A. The catalytic combustor breaks the bonds that hold the chemicals contained in wood smoke together. The result is that these chemicals begin to burn at temperatures of about 500 degrees F (the normal range of exhaust gas temperatures). Without the catalytic combustor, wood smoke would have to be brought up to a temperature of 1000 to 1200 degrees F in order to start to burn. A stove with a catalytic combustor will generate up to 25% more heat from each piece of wood, thus reducing the amount of fuel used during the year.

There are three advantages to burning the smoke created by burning wood. *First*, the smoke becomes another source of

fuel, giving you more heat from the same amount of wood. *Second*, creosote causing materials will be burned up instead of being deposited in your chimney, reducing the risk of a chimney fire. *Third*, air pollution will be drastically reduced.

Q. How can I tell if the catalytic combustor is working or “worn out”?

A. First - The best way to tell if the catalytic combustor is working is by observing the smoke coming out of your chimney. If there is only a small amount of smoke, and/or it's white in color, the catalytic combustor is working. You will see significantly more smoke when the combustor is being bypassed than when the smoke is being burned by the combustor.

Second - One very noticeable effect of a well functioning combustor is the high efficiency of your stove. Catalytic combustors produce lots of heat, which the stove radiates into your home. If you notice that the stove is producing less heat, or that a load of wood doesn't provide as much warmth, under similar circumstances, as it did before, it's time to check the combustor. If and when the catalyst ceases to function properly, the stove will produce noticeably less heat.

Third - Regular inspection of the connector pipe and chimney flue should show very little accumulation of soot and creosote. Soot is typically brown and powdery when the combustor is working properly. Heavy buildup of black sticky creosote may indicate the combustor is not functioning or needs cleaning.

If you suspect that your catalyst is not working, let the stove cool down and clean the combustor and try it again.

Q. How do I maintain my catalytic combustor?

A. Combustors should be inspected and cleaned if necessary **every 4-6 weeks** during the heating season. When the stove is cool, the combustor can be cleaned by thoroughly vacuuming or brushing both sides.

If the stove does not draft well when the catalytic combustor is engaged then the combustor cells themselves might be partially plugged with fly ash. If this is the case, follow the cleaning procedure described in detail on page 20 of this manual.

Q. Is it all right to burn my stove hot daily to clean any build up in my chimney system?

A. It is not necessary to burn your stove hot daily to burn off any creosote build up in the chimney. This function is performed by the catalytic combustor. It is there to reduce the emissions from the stove that contribute to deposits in the connector pipe and chimney flue.

View more frequently asked questions and articles at our web site www.woodstove.com. Other very useful websites on all aspects of wood burning are www.hearth.com, www.woodheat.org, and www.csia.org. CSIA is the Chimney Safety Institute of America.

TWO OTHER IMPORTANT POINTS REGARDING CATALYTIC COMBUSTORS:

- 1) The combustor uses wood smoke as fuel. Most smoke is created in the early stages of the burn cycle. When a bed of coals is all that remains of your wood, there is little smoke left to fuel the combustor, and it will no longer create substantial amounts of heat. Hence, the temperatures on the surface thermometer tend to fall toward the end of the burn, even though the firebox is full of hot coals. This does not mean that you have to reload the stove or open the bypass. Let the hot coals burn down to ashes.
- 2) Since the combustor blocks the path of exiting smoke, it can reduce the draft in your stove. When draft is reduced by warm or rainy weather, open the bypass damper longer when starting the stove to create more draft.

CATALYTIC COMBUSTOR WARRANTY

The catalytic combustor in your Ideal Steel Hybrid Woodstove is fully warranted for three years from the date of purchase against any defect in workmanship or materials that prevent the combustor from functioning when installed and operated properly. The catalytic combustor is additionally warranted for three years from the date of purchase for any deterioration in the stainless steel substrate material. For instructions regarding return or replacement of the catalytic combustor, please contact:

Woodstock Soapstone Company, Inc.
66 Airpark Road
West Lebanon, NH 03784
Phone: 1-800-866-4344 • Web: www.woodstove.com